

GAYLA TRI-PLANE KITE ASSEMBLY INSTRUCTIONS

BEFORE BEGINNING CAREFULLY READ THE INSTRUCTIONS. THEN PLACE THE BLACK BRACE PARTS INTO 4 GROUPS. ONE GROUP FOR EACH TYPE OF BRACE. SEE ILLUSTRATION ON RIGHT.

- BRACE A 10 PIECES APPROX. 7 INCHES (WING BRACES)
- BRACE B 4 PIECES APPROX. 10.5 INCHES (WING BRACES)
- BRACE C 4 PIECES APPROX. 13.5 INCHES (WING BRACES)
- BRACE D 2 PIECES APPROX. 24 INCHES (BODY BRACES)

STEP 1: ASSEMBLE WING CROSS BRACES

COMPLETELY ASSEMBLE ONE GROUP OF WING CROSS BRACES BEFORE ASSEMBLING ANOTHER. START ON THE TOP RIGHT SIDE OF PLANE. *NOTE: DON'T START FROM LEFT SIDE. THE BRACES WILL APPEAR DIFFERENT THAN INSTRUCTIONS AND YOU MAY ASSEMBLE CROSS BRACES BACKWARDS.*

TO ASSEMBLE: INSERT BRACES "A", "B" AND "C" INTO THE SOCKETS AT EDGES OF THE WINGS. THIS FORMS A WING CROSS BRACES GROUP. SEE ILLUSTRATION FOR PLACEMENT OF EACH GROUP.

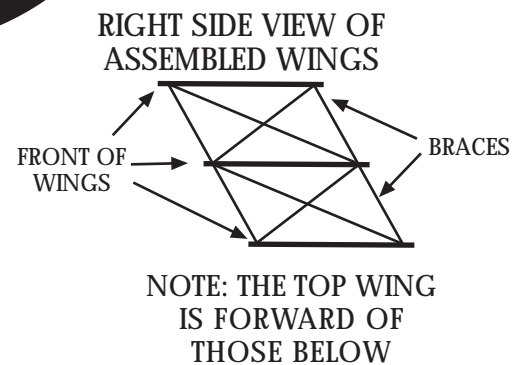
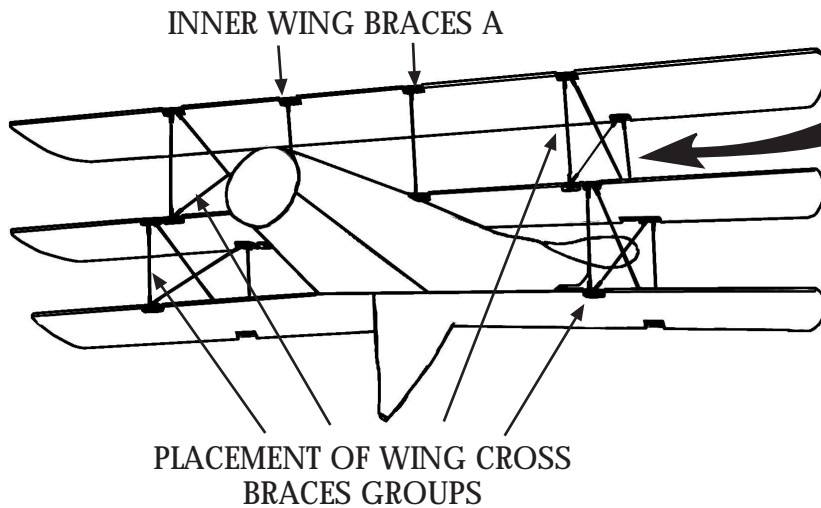
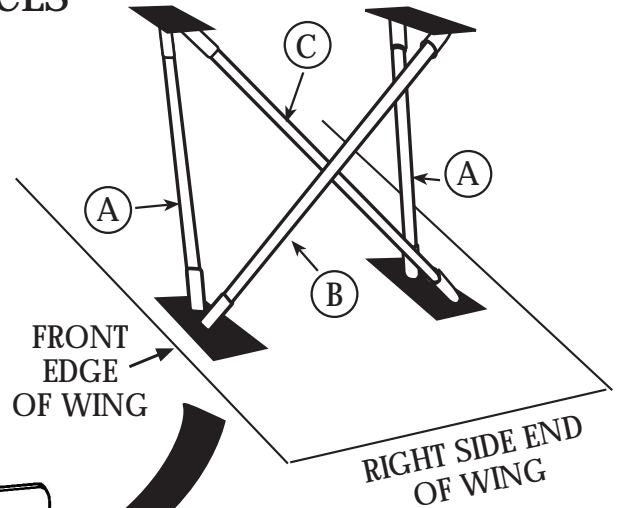

STEP 2: ASSEMBLE BODY BRACES

INSERT BODY BRACES "D" INTO MAIN BODY THROUGH THE LOOPS SEWN IN THE MIDDLE INSIDE THE KITE. CROSS BRACES AND PLACE BRACE ENDS INTO POCKETS AT EACH END OF KITE.

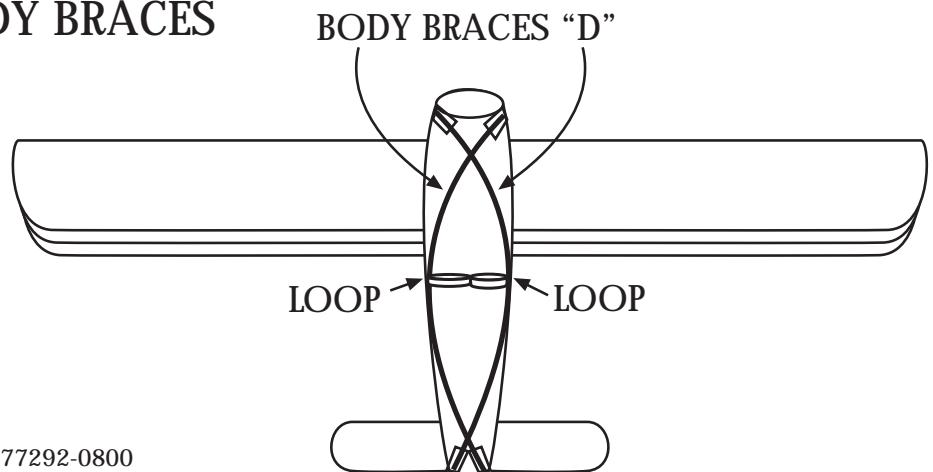

PO BOX 920800 HOUSTON TEXAS 77292-0800
WEB ADDRESS: www.gaylainc.com

GP 4481 MAY 31 01