

4. Spread the two longest sticks into a "X" shape. Insert the top of each stick into the wing stick cups. Insert the bottom of the sticks with the end caps into the holes in kite.

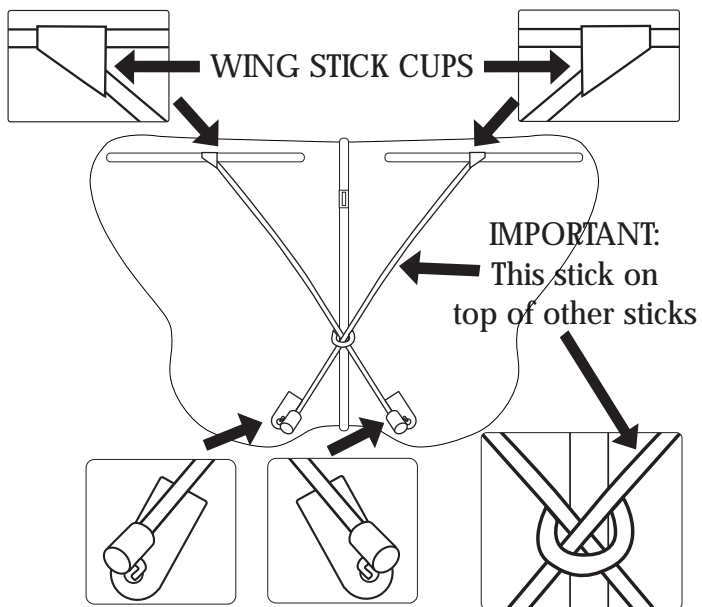

5. Insert the short kite stick into the top stick holder. Insert each end into each wing stick cup.

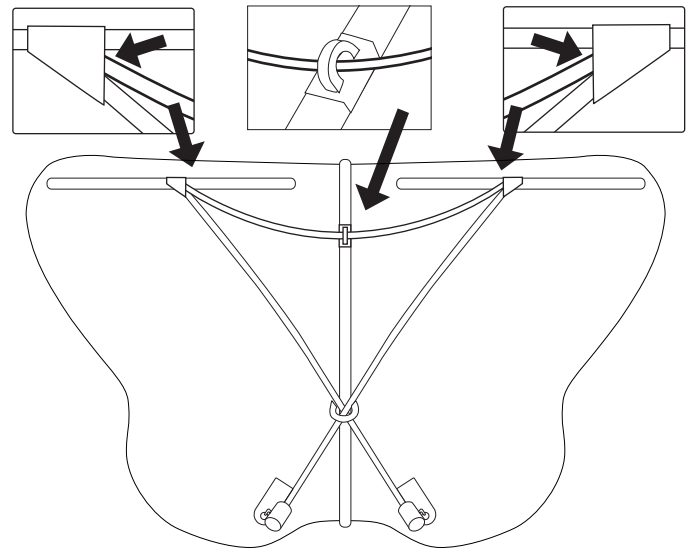

6. Peel off one wing reinforcement sticker and place it over the stick on the kite as shown. Press sticker down so the kite stick is touching the kite. Press firmly for a good seal. Repeat for the opposite side.

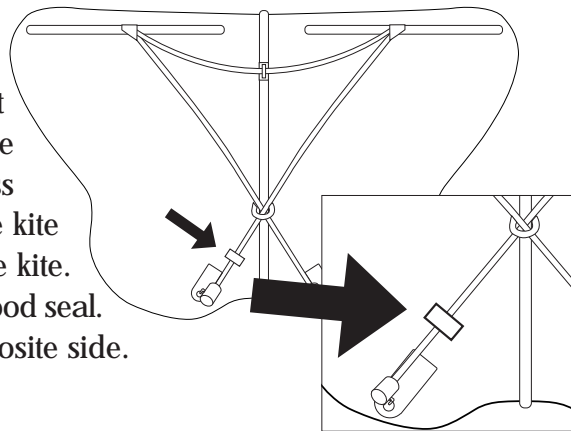

7. Position top two stickers approximately center between stick holder and wing stick cup.

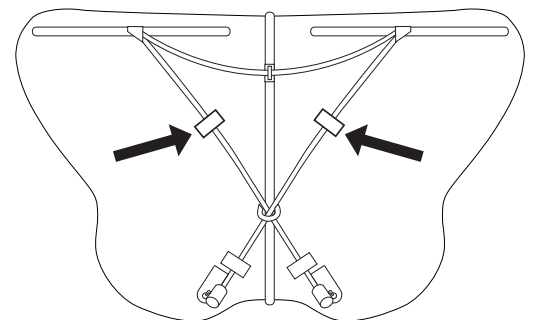

8. Place the top reinforcement sticker UNDER the top of the kite and align with sticks. The outlines of the kite sticks are printed on the sticker to guide you. After you understand where the sticker goes then peel the backing sheet off the BOTTOM PART of the reinforcement sticker. Place the sticker under kite as before and press the kite firmly to sticker. DO NOT PEEL OFF NARROW TOP PART OF THE STICKER AT THIS TIME.

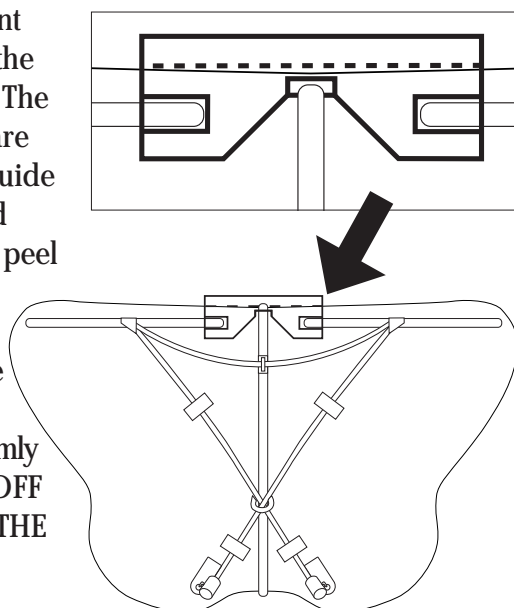

9. Peel the backing sheet off the narrow top part of the reinforcement sticker and fold over the top of kite to the other side and press firmly.

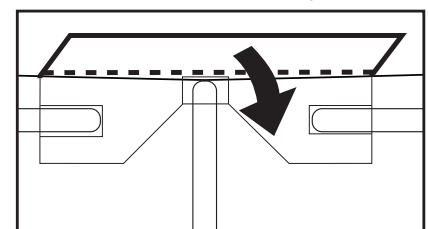

10. Tie string to kite keel. Kite is now ready to fly.

