



3-D KITE STOCK NO. 639,643

ASSEMBLY INSTRUCTIONS

BEFORE BEGINNING, CAREFULLY READ THE INSTRUCTIONS. NEXT, SEPARATE ALL PARTS INTO GROUPS ACCORDING TO THE ILLUSTRATION ON YOUR RIGHT. SEE ILLUSTRATIONS BELOW TO BEGIN.

PARTS LIST

 BRACE A APPROX. 7" 2 PIECES (WING STRUTS)

 BRACE B APPROX. 26" 2 PIECES (BODY BRACE)

WHEELS
2 OF 2

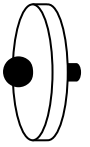

FRONT VIEW

STEP 1:

INSERT WING STRUTS

INSERT BRACES A TO WING AND WHEEL BRACE AS ILLUSTRATED. REPEAT STEP FOR OPPOSITE SIDE.

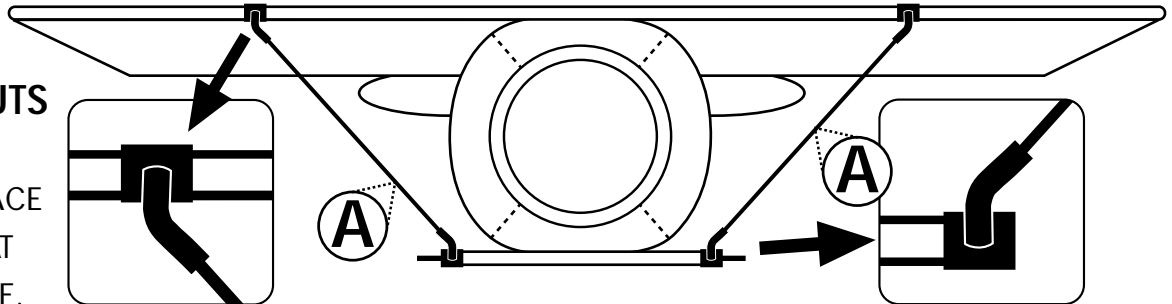

STEP 2:

INSERT BODY BRACES

INSERT BRACES B PARALLEL THROUGH TWO LOOPS LOCATED INSIDE THE PLANE BODY. CROSS THE BRACES AT THE TAIL AND NOSE ENDS. INSERT EACH END INTO POCKETS. LOOK AT ILLUSTRATION FOR REFERENCE.

TOP VIEW

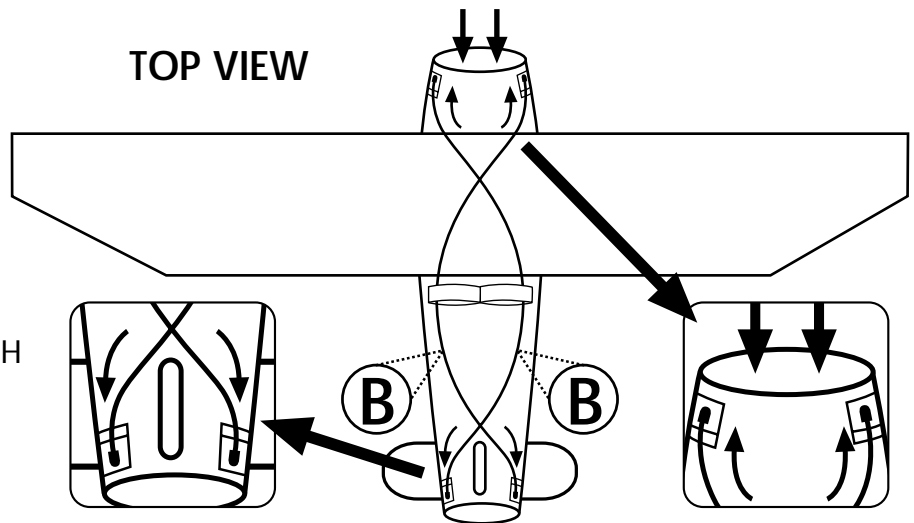

FRONT VIEW

STEP 3:

ATTACH WHEELS

ATTACH WHEELS TO WHEEL BRACE AS ILLUSTRATED. REPEAT STEP FOR OPPOSITE SIDE.

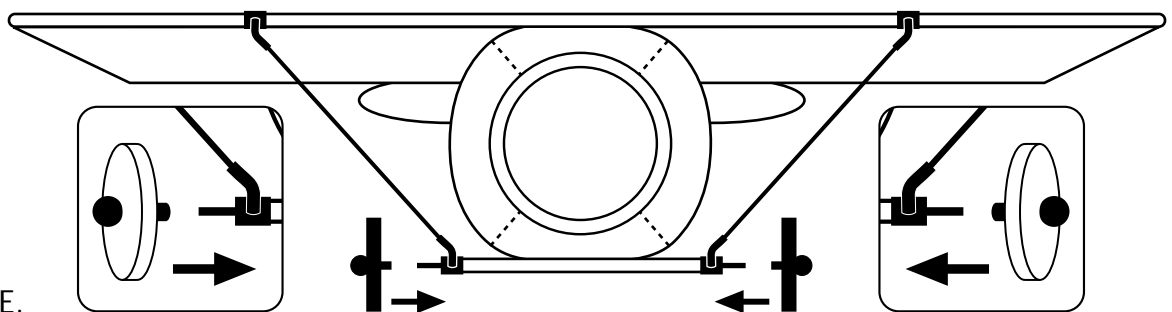

BOTTOM VIEW

STEP 4:

ATTACH SPINNING GYRO TAIL

LOCATE HOLE UNDERNEATH PLANE
TOWARDS THE TAIL END. OPEN
PIN ON END OF STRING ATTACHED
TO THE TAIL. INSERT THROUGH HOLE.
CLOSE TAIL PIN

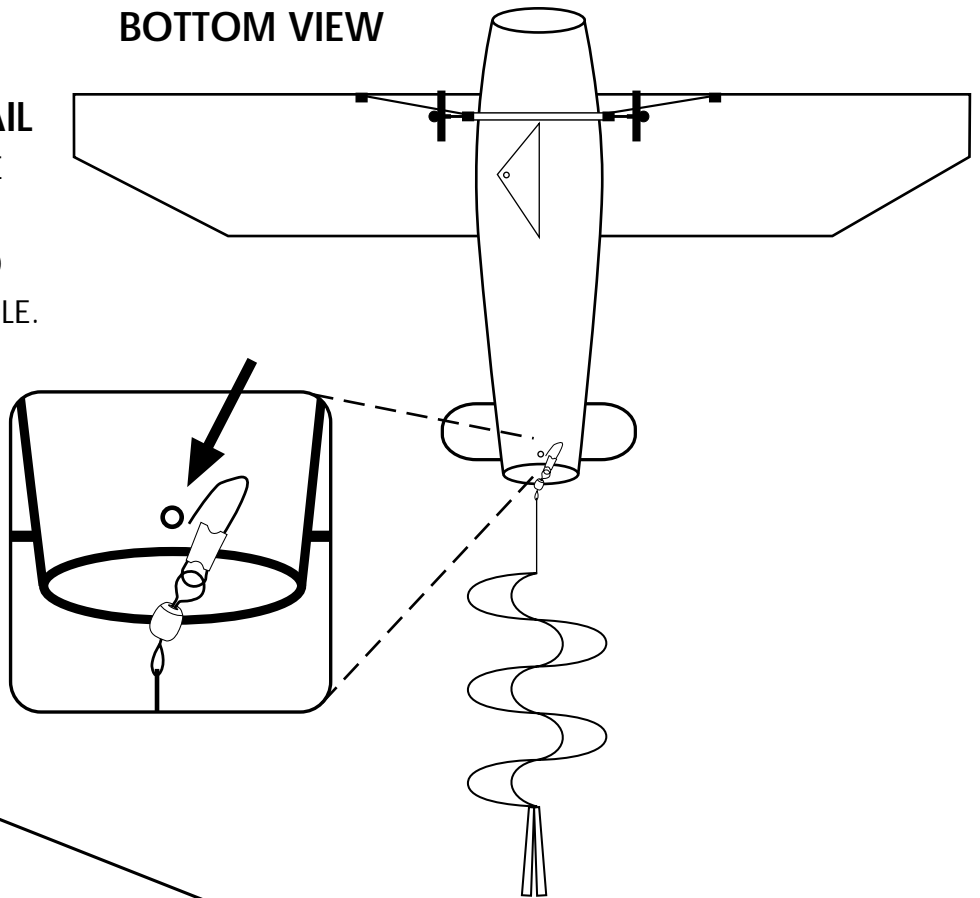

STEP 5:

ATTACH TWINE TO BRIDLE

LOCATE BRIDLE UNDERNEATH PLANE.
THE BRIDLE RUNS FROM THE NOSE
OF THE PLANE TO THE MID SECTION
OF THE PLANE. LOCATE THE LOOP
IN THE MIDDLE OF THE BRIDLE AND
TIE TWINE THROUGH THE LOOP.
NOW YOUR 3-D KITE IS READY TO FLY!

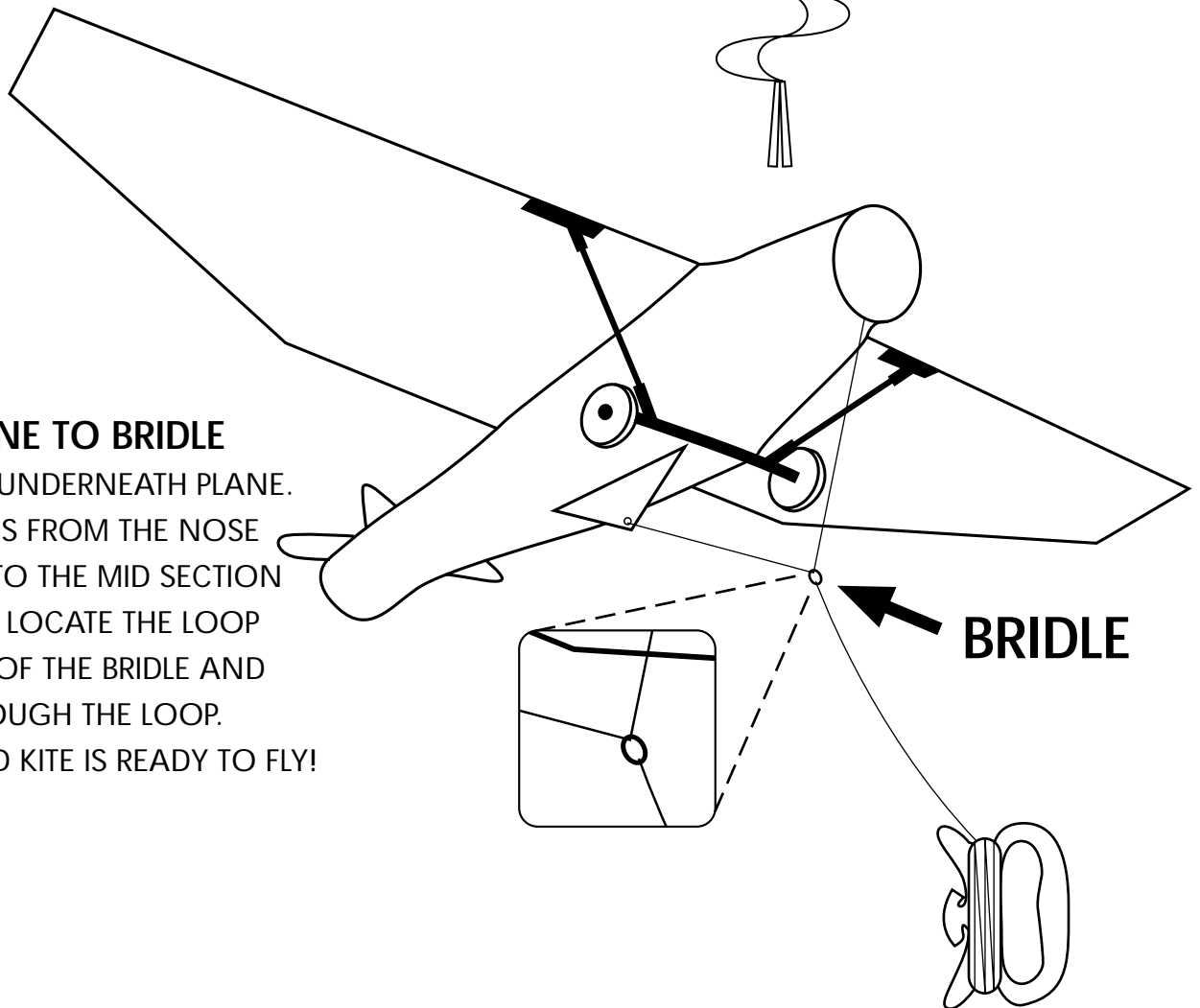

PO BOX 920800 HOUSTON TEXAS 77292-0880
WEB ADDRESS: www.gaylainc.com

3-D KITE STOCK NO. 639,643
ASSEMBLY INSTRUCTIONS
GP 4740 AUG 26 02 2 OF 2