

GAYLA BIPLANE KITE #642 ASSEMBLY INSTRUCTIONS

BEFORE BEGINNING CAREFULLY READ THE INSTRUCTIONS. THEN PLACE THE BLACK BRACE PARTS INTO 4 GROUPS. ONE GROUP FOR EACH TYPE OF BRACE. SEE ILLUSTRATION ON RIGHT.

- BRACE A** 4 PIECES APPROX. 6.5 INCHES (WING BRACES)
- BRACE B** 2 PIECES APPROX. 7 INCHES (WING BRACES)
- BRACE C** 2 PIECES APPROX. 13.5 INCHES (WING BRACES)
- BRACE D** 2 PIECES APPROX. 35 INCHES (BODY BRACES)

STEP 1: ASSEMBLE WING CROSS BRACES

COMPLETELY ASSEMBLE THE RIGHT SIDE FIRST THEN TURN THE PLANE AROUND AND ASSEMBLE THE LEFT SIDE. START ON THE TOP RIGHT SIDE OF PLANE. **NOTE: DON'T START FROM LEFT SIDE. THE BRACES WILL APPEAR DIFFERENT THAN INSTRUCTIONS AND YOU MAY ASSEMBLE CROSS BRACES BACKWARDS.**

TO ASSEMBLE: INSERT BRACES "A", "B" AND "C" INTO THE SOCKETS AT EDGES OF THE WINGS. THIS FORMS A WING CROSS BRACES GROUP. SEE ILLUSTRATION FOR PLACEMENT.

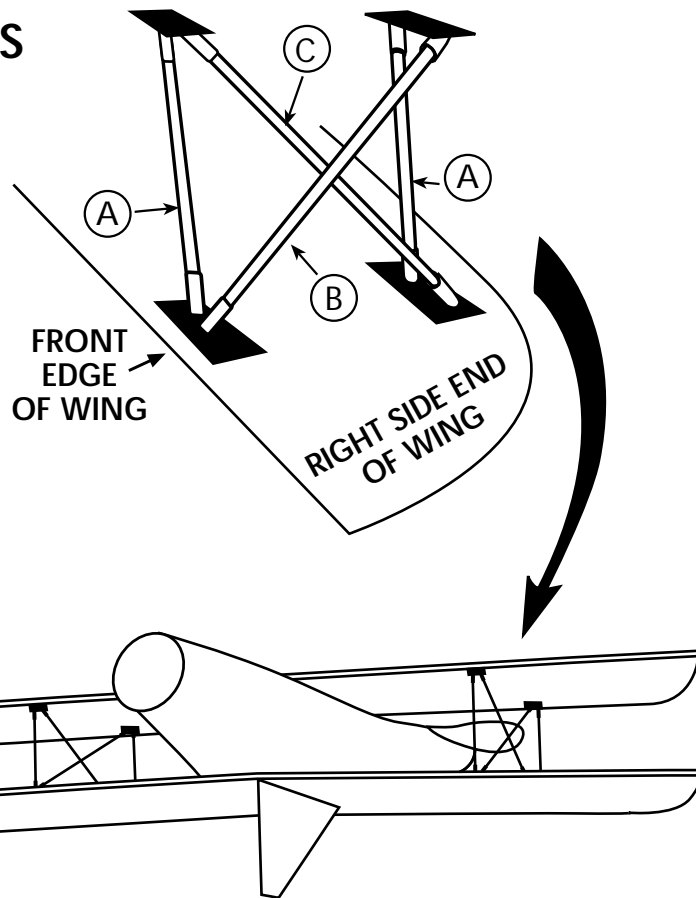

LEFT SIDE VIEW OF ASSEMBLED WINGS

RIGHT SIDE VIEW OF ASSEMBLED WINGS



NOTE: THE TOP WING IS FORWARD OF THOSE BELOW

STEP 2: ASSEMBLE BODY BRACES

INSERT BODY BRACES "D" INTO MAIN BODY THROUGH THE LOOPS SEWN IN THE MIDDLE INSIDE THE KITE. CROSS BRACES AT EACH END AND PLACE BRACE ENDS INTO POCKETS AT EACH END OF KITE. SEE ILLUSTRATION FOR PLACEMENT.

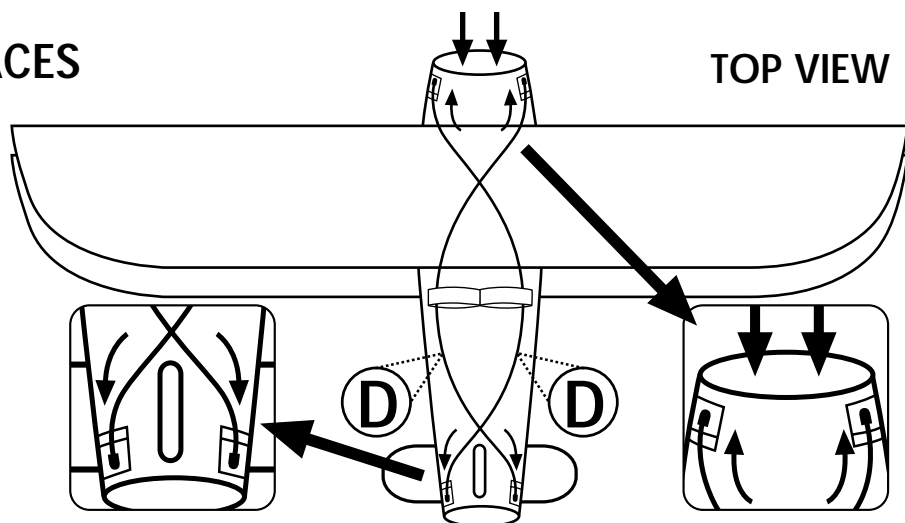

STEP 4:

ATTACH SPINNING GYRO TAIL

LOCATE HOLE UNDERNEATH PLANE
TOWARDS THE TAIL END. OPEN
PIN ON END OF STRING ATTACHED
TO THE TAIL. INSERT THROUGH HOLE.
CLOSE TAIL PIN

BOTTOM VIEW

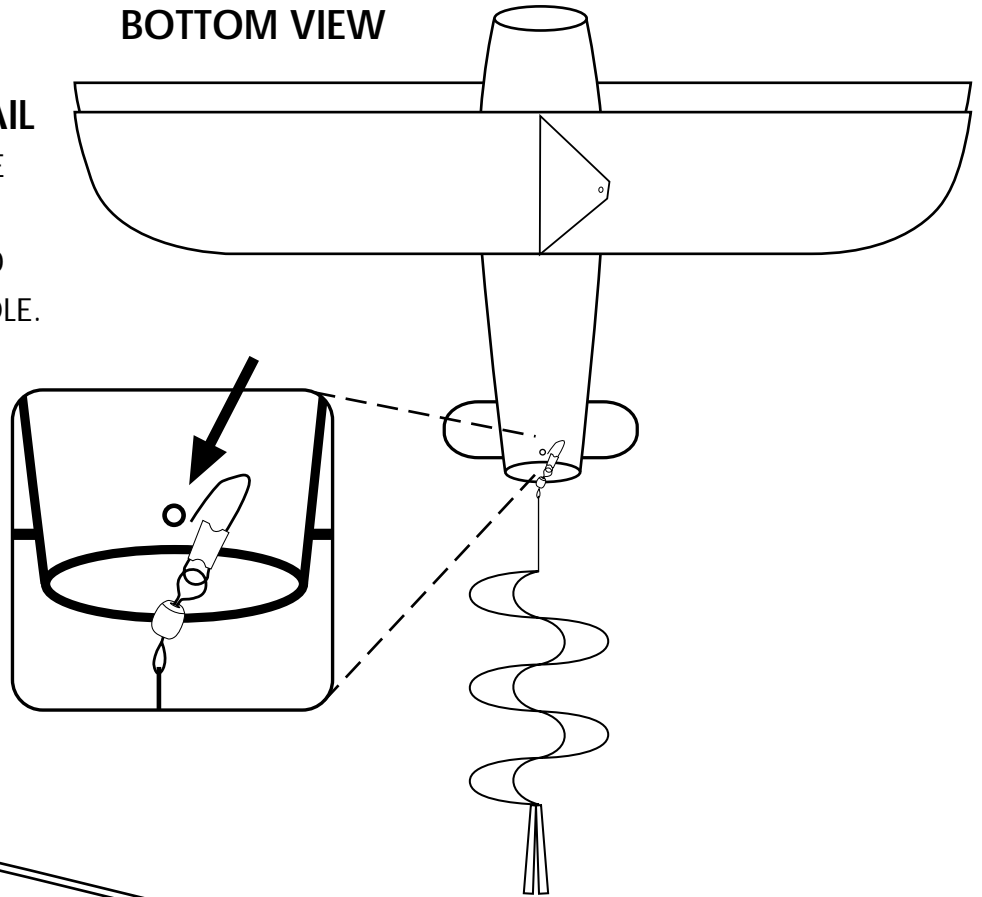

STEP 5:

ATTACH TWINE TO BRIDLE

LOCATE BRIDLE UNDERNEATH PLANE.
THE BRIDLE RUNS FROM THE NOSE
OF THE PLANE TO THE MID SECTION
OF THE PLANE. LOCATE THE LOOP
IN THE MIDDLE OF THE BRIDLE AND
TIE TWINE THROUGH THE LOOP.
NOW YOUR 3-D KITE IS READY TO FLY!

