

GAYLA 3-D KITE ASSEMBLY INSTRUCTIONS

FOR STOCK NO. 641, 646 AND 653

BEFORE BEGINNING, CAREFULLY READ THE INSTRUCTIONS.
NEXT SEPARATE ALL PARTS INTO GROUPS

BRACE A 2 EACH BODY BRACE



BRACE B MAIN WING BRACE



WHEEL ASSEMBLIES 2 EACH

STEP 1: ASSEMBLY OF BODY BRACES

INSERT BRACES A (BODY BRACES) PARALLEL THROUGH THE TWO SETS OF LOOPS LOCATED IN THE JET BODY. MAKE SURE THE BODY BRACES SET UNDER THE WING BRACES FOR SUPPORT. CROSS THE BODY BRACES AT EACH END AND SECURE IN POCKETS AT BOTH ENDS OF THE JET.

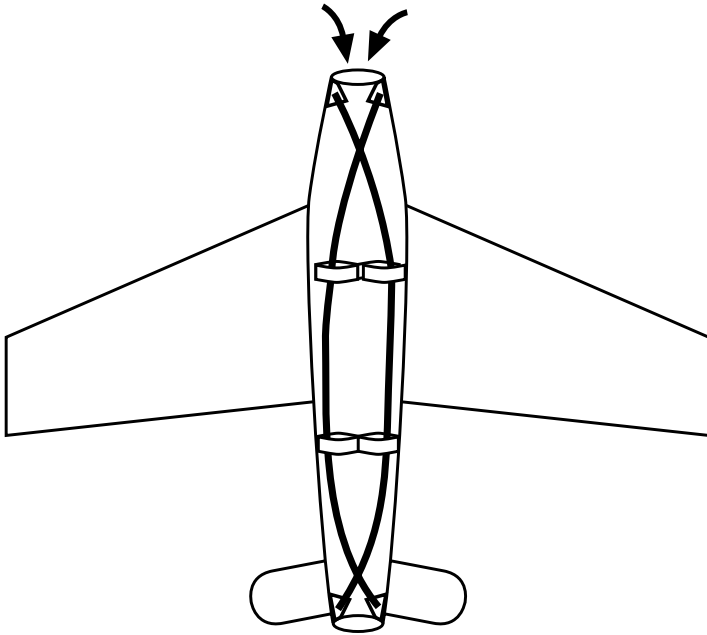

STEP 2: ASSEMBLY OF MAIN WING BRACE

REMOVE ONE WHEEL CONNECTOR FROM WING BRACE. INSERT BRACE B (MAIN WING BRACE) THROUGH THE HOLES LOCATED ON THE SIDE OF THE JET. REATTACH THE WHEEL CONNECTOR. INSERT THE WING BRACE INTO THE SLOTS ON EACH SIDE WING.

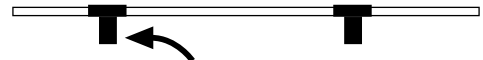

SLIDE OFF ONE WHEEL CONNECTOR TO INSERT INTO BODY AND REATTACH

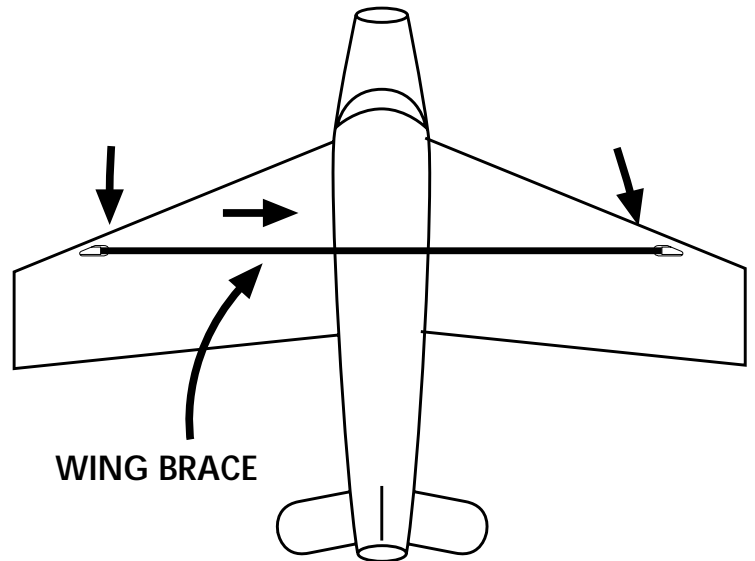

STEP 3: ASSEMBLE LANDING GEAR

INSERT WHEEL CONNECTORS THROUGH THE HOLES LOCATED IN THE WINGS. INSERT THE 2 WHEEL BRACES INTO WHEEL CONNECTORS.

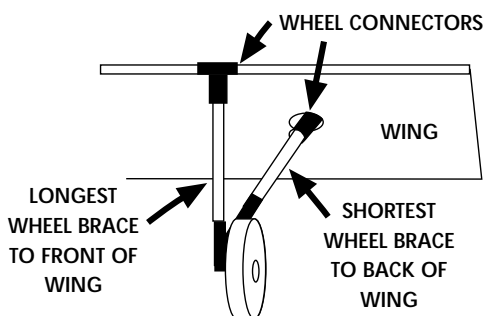

STEP 4: ATTACH SPINNING TAIL

LOCATE HOLE UNDERNEATH PLANE TOWARDS THE TAIL END. OPEN PIN ON END OF STRING ATTACHED TO THE TAIL. INSERT THROUGH HOLE. CLOSE TAIL PIN

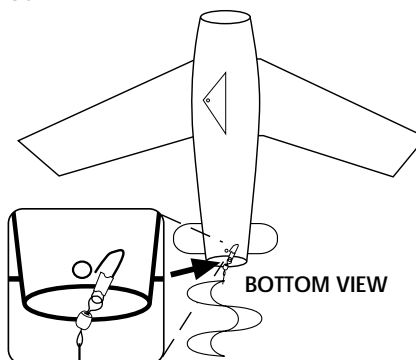

STEP 4: ATTACH KITE TWINE

LOCATE RING ON BRIDLE AND ATTACH TWINE.

