

GAYLA 3-D KITE 940 & 941 ASSEMBLY INSTRUCTIONS

BEFORE BEGINNING, CAREFULLY READ THE INSTRUCTIONS. THEN PLACE THE BLACK BRACE PARTS INTO 6 GROUPS. ONE GROUP FOR EACH TYPE OF BRACE AND ONE GROUP FOR THE RUBBER BANDS AND CONNECTORS SEE ILLUSTRATION BELOW

BRACE A 4 PIECES APPROX. 3.5 INCHES (PONTOON BRACES)

BRACE B 2 PIECES APPROX. 6 INCHES (PONTOON SUPPORT BAR)

BRACE C 2 PIECES APPROX. 7.25 INCHES (WING BRACES)

BRACE D 2 PIECES APPROX. 9.25 INCHES (WING SPREADER)

BRACE E 2 PIECES APPROX. 26.25 INCHES (BODY BRACES)



CONNECTOR 1
4 PIECES



CONNECTOR 2
4 PIECES



RUBBER BAND
4 PIECES

STEP 1: ASSEMBLE BODY & WING BRACES

INSERT BODY BRACES (E) INTO MAIN BODY OF KITE THROUGH LOOPS SEWN INSIDE THE KITE AND SECURE IN POCKETS AT EACH END.

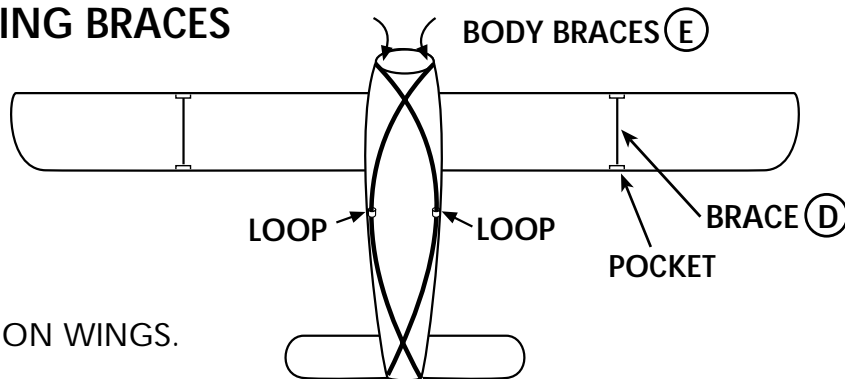

INSERT BRACES (D) INTO THE POCKETS ON WINGS.

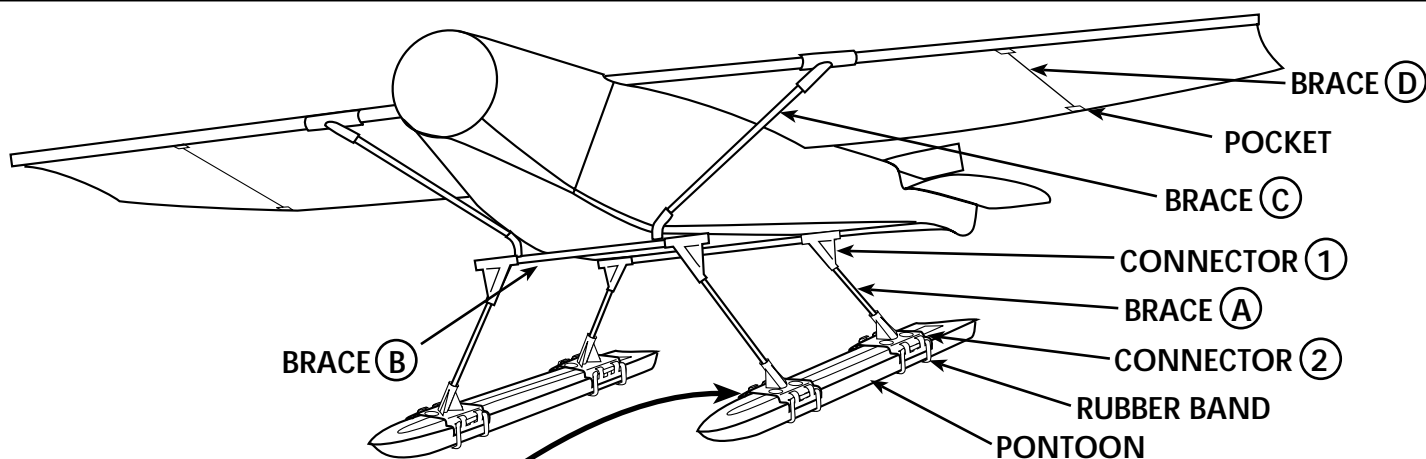

STEP 2: ASSEMBLE PONTOON & WING BRACES

INSERT BRACES (B) INTO SLEEVES AT BOTTOM OF PLANE.

PUSH CONNECTORS (1) ONTO BRACES (B).

INSERT BRACES (C) INTO SOCKETS NEXT TO CONNECTORS (1).

INSERT BRACES (A) INTO CONNECTORS (1) AND CONNECTORS (2)

ASSEMBLE PONTOON ONTO CONNECTORS (2) AS SHOWN.

STRETCH RUBBER BAND ACROSS CONNECTORS (2) AND PONTOONS AS SHOWN AT RIGHT.

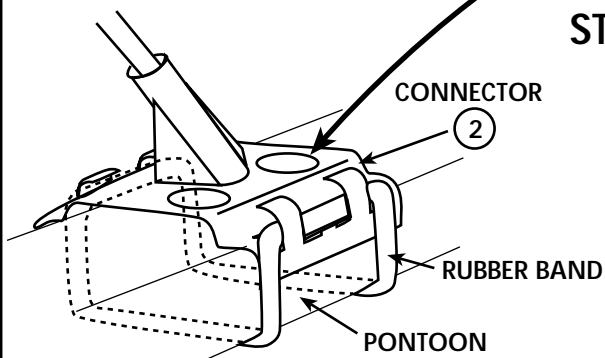

PO BOX 920800 HOUSTON TEXAS 77292-0800

WEB ADDRESS: www.gaylainc.com

GP 4738 AUG 15 02