

GAYLA 3-D KITE NO. 945

ASSEMBLY INSTRUCTIONS

BEFORE BEGINNING, CAREFULLY READ THE INSTRUCTIONS. NEXT, SEPARATE ALL PARTS INTO GROUPS ACCORDING TO THE ILLUSTRATION ON RIGHT.

BRACE A APPROX. 9.5" (VERTICAL TAIL BRACE)

BRACE B APPROX. 16.5" (TAIL WING BRACE)

BRACE C APPROX. 50" (MAIN WING BRACE)

BRACE D APPROX. 52" 2 OF 2 (BODY BRACE)

JET ENGINE
4 OF 4

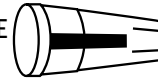

STEP 1

- ① INSERT **BRACE C** (MAIN WING BRACE) THROUGH THE HOLE LOCATED ON THE SIDE OF THE BODY. ② SECURE BRACE IN SLOTS ON EACH SIDE.
- ③ INSERT **BRACES D** (BODY BRACES) PARALLEL THROUGH THE TWO SETS OF LOOPS LOCATED IN THE JET BODY. MAKE SURE THE BODY BRACES SET UNDER THE WING BRACES. CROSS THE BODY BRACES AT EACH END AND SECURE IN POCKETS AT BOTH ENDS OF THE KITE.

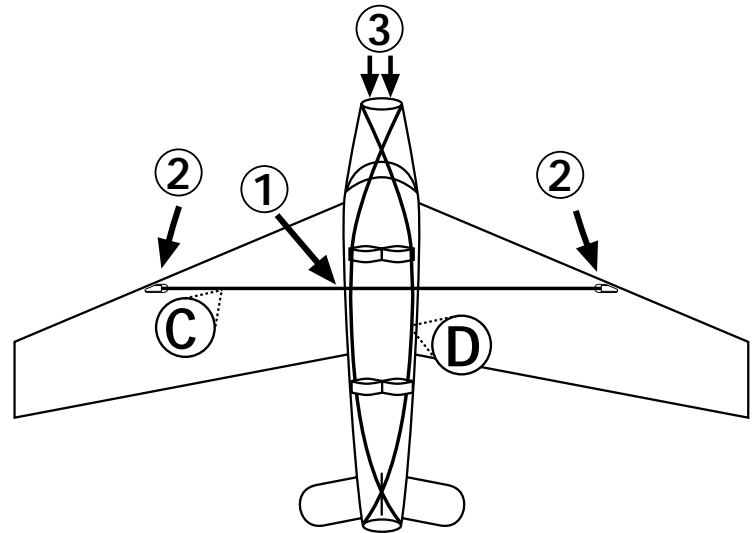

STEP 2

- ① INSERT **BRACE B** (TAIL WING BRACE) THROUGH THE HOLE LOCATED BY THE TAIL OF THE JET. ② SECURE BRACE IN POCKETS ON EACH SIDE.
- ③ INSERT **BRACE A** (VERTICAL WING BRACE) THROUGH THE SLEEVE LOCATED INSIDE THE TAIL OF THE JET. ④ SECURE BRACE IN POCKET ON INSIDE BOTTOM OF TAIL.

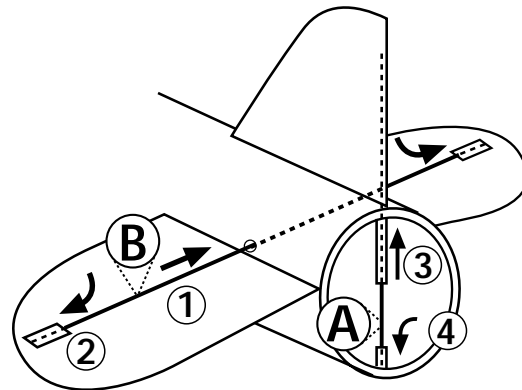

STEP 3

SECURE THE FOUR **JET ENGINES (E)** UNDERNEATH THE WINGS WITH THE VELCROW.

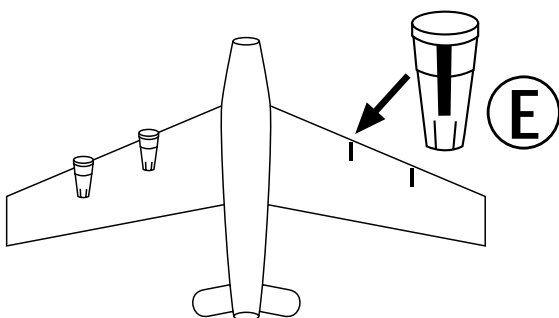

STEP 4

LOCATE **KEEL** UNDERNEATH THE JET AND TIE TWINE TO THE KEEL.

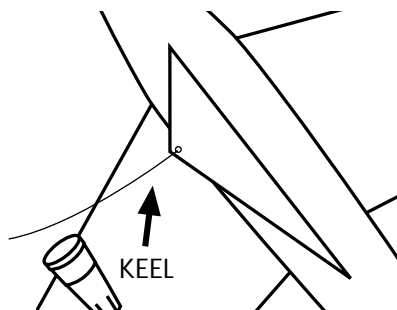

STEP 5

ATTACH SPINNING TAIL TO GROMMET HOLE UNDER JET TAIL.

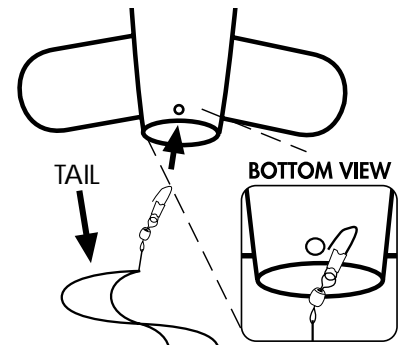

PO BOX 920800 HOUSTON TEXAS 77292-0800
WEB ADDRESS: www.gaylainc.com

945
GP 4798 NOV 21 02